

## Iron overload in the Asian community

Chun Yu Lok,<sup>1</sup> Alison T. Merryweather-Clarke,<sup>1,2</sup> Vip Viprakasit,<sup>1,3</sup> Yingyong Chinthammitr,<sup>4</sup> Somdet Srichairatanakool,<sup>5</sup> Chanin Limwongse,<sup>3</sup> David Olesky,<sup>6</sup> Anthony J. Robins,<sup>6</sup> John Hudson,<sup>7</sup> Phyu Wai,<sup>8</sup> Anuja Premawardhena,<sup>9</sup> H. Janaka de Silva,<sup>9</sup> Anuradha Dassanayake,<sup>10</sup> Carole McKeown,<sup>11</sup> Maurice Jackson,<sup>12</sup> Rousseau Gama,<sup>13,14</sup> Nasaim Khan,<sup>15</sup> William Newman,<sup>15</sup> Gurvinder Banait,<sup>16</sup> Andrew Chilton,<sup>17</sup> Isaac Wilson-Morkeh,<sup>17</sup> David J. Weatherall,<sup>1</sup> and Kathryn J.H. Robson<sup>1</sup>

<sup>1</sup>Medical Research Council Molecular Haematology Unit, Weatherall Institute of Molecular Medicine, and <sup>2</sup>Blood Research Laboratory, National Blood Service, John Radcliffe Hospital, Headington, Oxford, United Kingdom; Departments of <sup>3</sup>Paediatrics and <sup>4</sup>Internal Medicine, Siriraj-Thalassemia Research Program and World Health Organization Collaborating Center for the Control of Haemoglobinopathies, Faculty of Medicine Siriraj Hospital, Mahidol University, Bangkok, Thailand; <sup>5</sup>Department of Biochemistry, Faculty of Medicine, Chang Mai University, Chang Mai, Thailand; Departments of <sup>6</sup>Biochemistry, <sup>7</sup>Haematology, and <sup>8</sup>Endocrinology, Macclesfield Hospital, Macclesfield, United Kingdom; Departments of <sup>9</sup>Medicine and <sup>10</sup>Pharmacology, Faculty of Medicine, University of Kelaniya, Ragama, Sri Lanka; <sup>11</sup>Clinical Genetics, Birmingham Women's Hospital, Birmingham, United Kingdom; <sup>12</sup>Renal Unit and <sup>13</sup>Clinical Chemistry, New Cross Hospital, Wolverhampton, United Kingdom; <sup>14</sup>Research Institute, Healthcare Sciences, Wolverhampton University, Wolverhampton, United Kingdom; <sup>15</sup>Regional Genetic Service and Medical Genetic Research Group, St Mary's Hospital, Central Manchester and Manchester Children's Hospital National Health Service (NHS) Trust, Manchester, United Kingdom; <sup>16</sup>Royal Blackburn Hospital, Blackburn, United Kingdom; and <sup>17</sup>Kettering General Hospital NHS Foundation Trust, Kettering, United Kingdom

**Hereditary hemochromatosis is an iron overload disorder that can lead to the impairment of multiple organs and is caused by mutations in one or more different genes. Type 1 hemochromatosis is the most common form of the disease and results from mutations in the *HFE* gene. Juvenile hemochromatosis (JH) is the most severe form, usually caused by mutations in hemojuvelin (*HJV*) or hepcidin (*HAMP*). The autosomal dominant form of the disease, type 4, is due**

**to mutations in the *SLC40A1* gene, which encodes for ferroportin (FPN). Hereditary hemochromatosis is commonly found in populations of European origin. By contrast, hemochromatosis in Asia is rare and less well understood and can be masked by the presence of iron deficiency and secondary iron overload from thalassemia. Here, we provide a comprehensive report of hemochromatosis in a group of patients of Asian origin. We have identified novel mutations**

**in *HJV*, *HAMP*, and *SLC40A1* in countries not normally associated with hereditary hemochromatosis (Pakistan, Bangladesh, Sri Lanka, and Thailand). Our family studies show a high degree of consanguinity, highlighting the increased risk of iron overload in many countries of the developing world and in countries in which there are large immigrant populations from these regions. (Blood. 2009;114:20-25)**

### Introduction

Hemochromatosis is a disorder characterized by excessive iron absorption from the diet leading to iron overload in multiple organs and eventual toxicity. It is a genetically heterogeneous disease caused by mutations in one or more different genes. The most common form is due to mutations in the *HFE* gene (type 1), whereas juvenile hemochromatosis (JH), although less common, is the most severe form of the disease, with clinical symptoms that include cardiomyopathy and hypogonadotropic hypogonadism. JH is usually a result of mutations in hemojuvelin (*HJV*) or, more rarely, in hepcidin (*HAMP*).<sup>1,2</sup> An autosomal dominant form of hemochromatosis (type 4) is due to mutations in the *SLC40A1* gene. *SLC40A1* encodes ferroportin (FPN), a transmembrane iron exporter that can be inhibited by the peptide hormone hepcidin, thereby restricting iron uptake and release.<sup>3</sup> Further evidence shows that hepcidin itself is up-regulated by hemojuvelin by the bone morphogenetic protein (BMP) signaling pathway.<sup>4</sup>

*HFE*-hemochromatosis is mostly found in populations of European origin and almost always results from 2 mutations, H63D and C282Y.<sup>5</sup> In addition, a steadily increasing number of causative non-*HFE* hemochromatosis mutations are being identified and, like

type 1 hemochromatosis, they have been most frequently described in patients originating from Europe, including Greece, Italy, and the United Kingdom.<sup>1,2,6</sup> Commonly recurring mutations include G320V in hemojuvelin and V162del in ferroportin.

In contrast, reports of hemochromatosis in regions of Asia have been relatively rare, and the condition is less well defined. In these particular regions, the association of *HFE* mutations with iron overload is minimal and varied.<sup>7-15</sup> There have only been a few brief reports of non-*HFE* hemochromatosis in Asia, which appear to be isolated mutations with most cases around Eastern Asia.<sup>16-18</sup> In the Indian subcontinent, reports are even fewer with only 2 cases of type 4 hemochromatosis identified and no cases of JH.<sup>19,20</sup> At present, a difficulty with recognizing hereditary hemochromatosis in some parts of Asia is the presence of hemoglobin disorders such as thalassemia and the resulting secondary iron overload.<sup>21</sup> Furthermore, the presentation of the disease may also be masked by iron deficiency in these developing countries.<sup>22</sup>

To gain a better understanding of the genetic background of hemochromatosis in Asia, we studied a series of patients with unexplained iron overload originating from different regions. Here

Submitted January 13, 2009; accepted March 18, 2009. Prepublished online as *Blood* First Edition paper, April 2, 2009; DOI 10.1182/blood-2009-01-199109.

An Inside *Blood* analysis of this article appears at the front of this issue.

The online version of this article contains a data supplement.

The publication costs of this article were defrayed in part by page charge payment. Therefore, and solely to indicate this fact, this article is hereby marked "advertisement" in accordance with 18 USC section 1734.

© 2009 by The American Society of Hematology

**Table 1. Identified hemochromatosis mutations and their origin**

Family	Protein	Exon	Nucleotide change	Amino acid change	Origin
A	Hemojuvelin	3	239G>A	C80Y	Bangladesh
B, C	Hemojuvelin	3	295G>A	G99R	Pakistan
D	Hemojuvelin	3	575C>T	P192L	Pakistan
E	Hemojuvelin	3	581T>C	L194P	Pakistan
F	Hemojuvelin	4	1026delT	A343PfsX23	Sri Lanka
G	Hepcidin	2	126-127delAG	R42Sfs	Pakistan
H	Ferroportin	7	977G>A	C326Y	Thailand

we present, for the first time, details of a group of patients with juvenile hemochromatosis from the Indian subcontinent and type 4 hemochromatosis from Southeast Asia. Several families from the Indian subcontinent were found to carry novel *HJV* and *HAMP* mutations and a mutation in ferroportin was identified in Thailand, where non-*HFE* hemochromatosis has never previously been characterized. These findings suggest that primary iron overload may not be as rare as was previously thought in these geographic areas.

## Methods

### Patients

Informed consent for molecular studies was obtained from all persons described here in accordance with the Declaration of Helsinki. We received hemochromatosis-gene testing requests for a total of 32 unrelated patients originating from the Indian subcontinent and Thailand with unexplained iron overload. All cases were unrelated to *HFE* hemochromatosis and have not been transfused. Eight of these cases, from 8 different families totaling 42 members, form the basis of this study. Healthy subjects of similar ethnic origin were used as controls. Institutional review board approval for this study was obtained from all participating institutions.

### Genetic analysis

Patients' genomic DNA was extracted from whole-blood samples using the QIAamp DNA Blood Midi Kit (QIAGEN, Dorking, United Kingdom) according to the manufacturer's protocol. The coding regions and splice sites of the hemojuvelin, hepcidin, transferrin receptor 2, and ferroportin genes were amplified for screening. Polymerase chain reactions (PCRs) were carried out with the use of AmpliTaq or AmpliTaq Gold DNA polymerase (ABI Applied Biosystems, Foster City, CA) and in the presence of Pwo SuperYield proofreading enzyme (Roche Diagnostics, Mannheim, Germany), according to manufacturer's instructions. Denaturing high-pressure liquid chromatography (DHPLC) was used to screen for mutations in all amplicons with the use of standard conditions. DHPLC was carried out on a WAVE Nucleic Acid Fragment Analysis System (Transgenomic, Omaha, NE) and analyzed using the Navigator software (Transgenomic Inc.) according to the manufacturer's instructions. Amplicons with elution

profiles containing a heteroduplex peak indicating a sequence variation were sequenced directly with the use of the ABI PRISM BigDye Terminator Sequencing Kit version 3.1 (ABI Applied Biosystems) and purified with the use of the DyeEx 2.0 Spin Kit (QIAGEN). Automated fluorescent sequencing was performed on an ABI PRISM 3100 Capillary Sequencer (Hitachi; ABI Applied Biosystems). Primer pairs and specific conditions for amplifying and screening of the genes are provided in the supplemental data (supplemental Tables 1-5, available on the *Blood* website; see the Supplemental Materials link at the top of the online article).

## Results

The country of origin of the probands together with the mutations identified are summarized in Table 1. Clinical, genetic, and laboratory findings are summarized in Tables 2 and 3. The sequence analysis of the mutations is provided in the supplementary data (supplemental Figure 1). All the mutations causing JH in families A to G were absent in 100 South Asian control chromosomes. There was no evidence of cardiac complications in any of the patients.

### Family A

The proband first presented at the age of 19 years with diabetes and raised iron parameters (Table 2). Endocrine tests were also abnormal. DHPLC and sequence analysis showed that the proband is a compound heterozygote for 2 single nucleotide missense mutations in *HJV*, a novel cysteine-to-tyrosine mutation at position 80 (C80Y) and the common glycine-to-valine mutation at position 320 (G320V; Tables 1 and 2). Her father is of Bangladeshi origin, and her mother is British. Neither were available for genetic testing. The G320V mutation is frequently described in families of European origin and has not previously been reported in Asians. For this reason, it is likely that the patient inherited the G320V mutation from her British mother and the novel C80Y mutation from her father. This C80Y mutation is the first *HJV* mutation to be found in the Bangladeshi population.

**Table 2. Genotype and phenotype of JH probands from the Indian subcontinent**

Family/ patient	Sex	Age at diagnosis, y	Tsat, %	Ferritin, $\mu\text{g/L}$	Hypogonadism	Diabetes	Liver biopsy	HJV mutation	HAMP mutation
A	F	19	100	5293	+	+	ND	C80Y/G320V	WT
B/IV-6	M	26	Raised	4485	+	+	IE, C	G99R	WT
C	F	11	ND	3772	ND	ND	IE	G99R	WT
D	M	23	Raised	>6000	+	ND	IE, C	P192L	WT
E	M	32	100	3756	+	-	IE, F	L194P	WT
F	M	17	94	5999	+	+	IE, F	A343PfsX23	WT
G	M	21	>97	5686	+	-	ND	WT	R42Sfs

All patients shown are homozygous for their mutations except the proband in family A, who is a compound heterozygote. Normal values for transferrin saturation (Tsat) were 15%-45%; ferritin, 15-200  $\mu\text{g/L}$  for females, 40-300  $\mu\text{g/L}$  for males. + indicates presence of symptom; -, absence of symptom; ND, not determined; IE, iron excess; C, cirrhosis; and F, fibrosis.

**Table 3. Genotype and phenotype of family H from Thailand with type 4 hemochromatosis**

Sex	Age at diagnosis, y	Iron indices					MCV, fL	Hb, g/dL	HbA <sub>2</sub> , %	MCH, pg	FBS, mg/dL	ALT, U/L	AST, U/L	FPN mutation
		Tsat, %	Ferritin, $\mu$ g/L	SI, $\mu$ mol/L	TIBC, $\mu$ mol/L									
M	47	95.9	4232	56.6	59.1	101	12.4	2.2	35.1	300	85	67	C326Y/WT	
F	41	93.8	481	74.0	78.9	101	14.1	2.6	35.0	83	24	26	C326Y/WT	
M*	38	99.6	4326	66.1	66.4	99	15.5	2.4	33.0	90	101	66	C326Y/WT	
F	33	80.0	552	52.9	66.4	103	13.7	2.4	34.4	81	31	28	C326Y/WT	

Normal values for transferrin saturation (Tsat) were 15%-45%; ferritin, 15-200  $\mu$ g/L for females, 40-300  $\mu$ g/L for males; serum iron (SI), 10-30  $\mu$ mol/L; total iron binding capacity (TIBC), 40-75  $\mu$ mol/L; mean corpuscular volume (MCV), 80-95 fL; Hb, 11.5-15.5 g/dL for females, 13.5-17.5 g/dL for males; HbA<sub>2</sub>, < 3.5%; mean corpuscular hemoglobin (MCH), 27-34 pg; fasting blood sugar (FBS), 70-100 mg/dL; alanine aminotransferase (ALT), <40 U/L; and aspartate aminotransferase (AST), <37 U/L.

\*Proband.

### Family B

The proband IV-6 (Figure 1), from Pakistan, was first diagnosed with diabetes and secondary infertility at the age of 26 years (Table 2). He was also diagnosed as having osteoporosis. He is married to his cousin once removed (V-2), and his parents are multiply consanguineous (Figure 1). Mutation detection showed that he is homozygous for a single nucleotide mutation, causing a change from glycine to arginine at position 99 of hemojuvelin (G99R; Table 1). This mutation has previously been reported in the Albanian population.<sup>6</sup> The proband's 3 siblings and aunt (III-8), who are unaffected, are heterozygous for G99R.

### Family C

A second patient from Pakistan, unrelated to family B, was also found to be homozygous for the HJV G99R mutation (Table 2). There was no family history of liver disease. She was identified after routine screening for general malaise and recurrent urinary tract infections, although we cannot confirm whether this is a direct consequence of the genetic hemochromatosis.

### Family D

The proband, from Pakistan, presented at age 23 years with secondary infertility (Table 2). He also experienced pain in his ankles and knees. He was found to be homozygous for a novel missense mutation in *HJV*, the substitution of proline 192 by leucine (P192L; Table 1). His parents and 6 of his 10 siblings are heterozygous for this mutation, whereas another 3 siblings are homozygotes. A sister, who is a homozygote aged 31 years, has a raised transferrin saturation and ferritin. One brother has biopsy-

proven cirrhosis, and a further brother is awaiting a liver biopsy, but tests to date suggest that he has cirrhosis. Four of the siblings have married their paternal first cousins. Only one sibling is wild-type.

### Family E

The proband, also from Pakistan, first presented with abnormal liver function tests at age 32 years. There was no evidence of diabetes (Table 2). Mutation analysis showed that he is homozygous for a novel single nucleotide substitution, resulting in a change from leucine to proline at position 194 (L194P; Table 1). This patient, in comparison to the other patients with JH described in this study, appears to have a slightly later presentation of hemochromatosis.

### Family F

The proband, a Sri Lankan male and the son of a non-consanguineous marriage, first presented at age 17 years with rapid weight loss, polyuria, and hyperpigmentation (Table 2). Liver function tests were also abnormal. There were no features of arthritis. Subsequent mutation detection found the proband to be homozygous for a novel single nucleotide T deletion in exon 4 of *HJV* (Table 1), resulting in a frameshift. If the transcripts were to be translated we predict a novel 23 amino acid extension after residue 342 before a premature stop codon results in a truncated protein with a total length of 365 residues. His father was heterozygous for this mutation. His mother was unavailable for study.

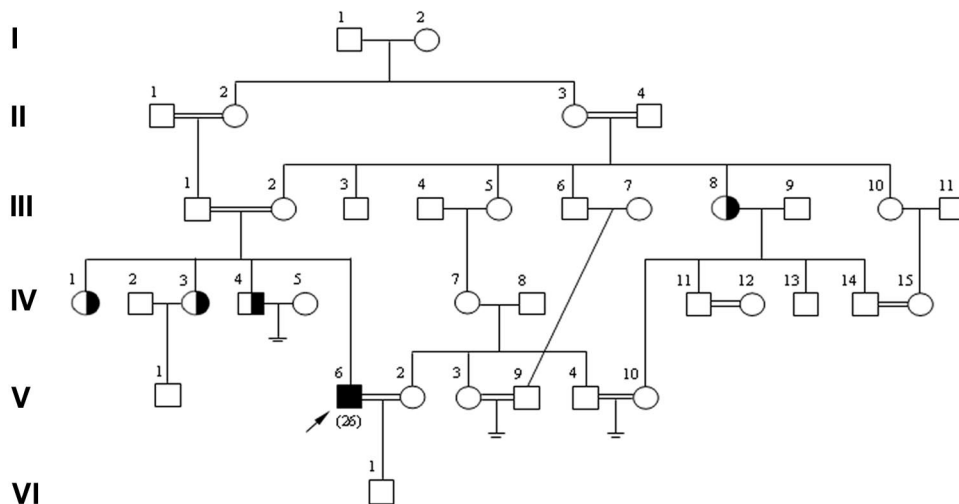

**Figure 1. Pedigree of family B with the HJV G99R mutation.** The proband (IV-6) is married to his cousin once removed (V-2), who is wild type. Only the proband, his wife, siblings, and aunt (III-8) were available for testing. Arrow indicates proband. Age at diagnosis is shown in parentheses.

### Family G

The proband, from Pakistan and son of multiply consanguineous parents, first presented with hypogonadotrophic hypogonadism, gynecomastia, and increased liver enzyme activity at age 21 years (Table 2). He has now been venesected 50 times with normalization of liver enzymes. He was found to be homozygous for a 2-nucleotide AG deletion in exon 2 of *HAMP* (Table 1). This novel deletion alters the reading frame after the first 41 amino acid residues of the protein and extends beyond the stop codon of the normal transcript. This completely disrupts the expression of the active peptide, which is entirely encoded by exon 3. The proband's parents, who were first cousins, are heterozygotes for the deletion and have normal iron indices. The brother of the proband is also a heterozygote with normal iron levels, but a sister is an affected homozygote aged 24 years.

### Family H

The proband, a 38-year-old Thai, was first detected as having abnormal liver function tests (Table 3). He had no evidence of arthritis, diabetes, or an inherited hemoglobin disorder. The proband's older brother (47 years old), who had a history of hyperpigmentation, impotence (aged 41), and diabetes (aged 43), was observed to have similar iron and liver function profiles to the proband. Two sisters who were clinically well at presentation also had raised iron parameters (Table 3). The proband tolerated venesection treatment well. Mutation analysis found him to be heterozygous for a cysteine-to-tyrosine change at position 326 (C326Y) in FPN (Table 1). The older brother and 2 sisters were also found to be heterozygous for this FPN mutation, whereas a further 3 siblings were wild type. Seven common  $\alpha$ -thalassemias caused by deletions ( $-\text{SEA}$ ,  $-\text{FIL}$ ,  $-\text{THAI}$ ,  $-\text{MED}$ ,  $-\alpha^{20.5}$ ,  $-\alpha^{3.7}$ , and  $-\alpha^{4.2}$ ) were excluded by Gap-PCR analysis using standard conditions, and hemoglobin analysis for all members of the family showed normal HbA and A<sub>2</sub> levels, therefore excluding secondary iron overload because of thalassemia. PCR RFLP using *Sfa*NI digestion was used to confirm the mutation, which was not detected in 600 other Thai and 200 Vietnamese chromosomes from healthy controls screened, confirming that C326Y is a causative mutation.

## Discussion

We report several novel mutations in *HJV*, *HAMP*, and *SLC40A1* that result in different presentations of iron overload, originating from countries not normally associated with hemochromatosis (Figure 2). To date, data on iron overload in the Indian subcontinent and Southeast Asia have been minimal. We and others have previously searched for the common *HFE* alleles in those regions and found them to be rare.<sup>10,23,24</sup> The only reports of *HFE*-associated hemochromatosis have been an *HFE* splice-site mutation of Vietnamese origin and a case of C282Y homozygosity in Japan.<sup>25,26</sup> We have also shown that the H63D and C282Y mutations arose independently in Sri Lanka.<sup>27</sup> Until now, only a few isolated cases of non-*HFE* hemochromatosis have been reported, and most cases of iron overload are due to secondary hemosiderosis. Nevertheless, the remarkable variation in the degree of iron loading in patients with non-transfusion-dependent forms of  $\alpha$ - and  $\beta$ -thalassemia intermedia<sup>11,21,28-31</sup> from similar

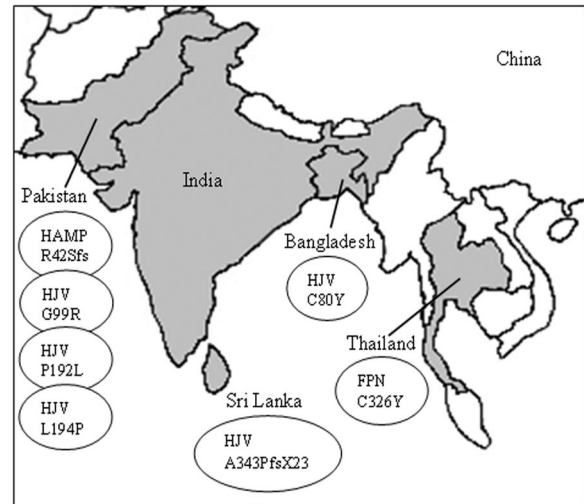

Figure 2. New non-*HFE* hemochromatosis mutations in Asia.

Asian environments suggest that hereditary hemochromatosis may be more common than previously thought, although to date no causal mutations have been identified.

All the mutations identified here are located in highly conserved regions of the proteins. There has been a previous report of a HJV C80R mutation in whites,<sup>32</sup> whereby the cysteine is replaced by arginine rather than the tyrosine mutation of Bangladeshi origin that we describe here. This suggests that C80 is an important residue of the protein. The first report of the HJV G99R mutation was of Albanian origin,<sup>6</sup> and our discovery of this mutation in 2 independent cases from the Pakistani population indicates that it is a recurrent mutation not restricted to Europe and may be the common mutation in this region. The G99 residue is located in the highly conserved RGD (Arg-Gly-Asp) motif of the protein; the first mutation reported to affect this position was G99V.<sup>1</sup> In other proteins the RGD motif has been shown to be a general integrin binding motif.<sup>33</sup> It has been shown that HJV N-terminal mutants, including those at positions C80 and G99, are able to reach the plasma membrane but not able to activate hepcidin, suggesting that N-terminal mutants are unable to interact correctly with signaling molecules such as the BMP receptors.<sup>34</sup> The HJV C-terminal mutants, conversely, appear to be retained in the endoplasmic reticulum and fail to reach the plasma membrane.<sup>35</sup>

HJV is a member of the repulsive guidance molecule (RGM) family and is highly conserved among different species from mouse to zebrafish. For all the residues affected by the HJV mutations, an equivalent identical residue can be found across different species and the other RGM family proteins, with the exception of L194 (Figure 3). Both the P192 and L194 residues lie in the partial von Willebrand factor D domain of the protein. However, leucine 194 is only found in HJV from mammals. This might explain the later onset of the disease in the proband in family E, because the semiconservative nature of the residue may have a less adverse affect on protein function. As judged by their early age of onset and high frequency of hypogonadism, with one exception, these Asian patients with JH have a very similar clinical phenotype to that described in this condition in developed countries. The lack of any evidence of cardiac involvement is surprising and could reflect the occurrence of the disease in a different environment or genetic background. This important issue remains to be explored further.



- hereditary haemochromatosis. *Nat Genet.* 1996; 13:399-408.
6. Lanzara C, Roetto A, Daraio F, et al. Spectrum of hemochromatosis gene mutations in 1q-linked juvenile hemochromatosis. *Blood.* 2004;103:4317-4321.
  7. Mortimore M, Merryweather-Clarke AT, Robson KJ, Powell LW. The haemochromatosis gene: a global perspective and implications for the Asia-Pacific region. *J Gastroenterol Hepatol.* 1999;14:838-843.
  8. Tsui WM, Lam PW, Lee KC, et al. The C282Y mutation of the HFE gene is not found in Chinese haemochromatosis patients: multicentre retrospective study. *Hong Kong Med J.* 2000;6:153-158.
  9. Shiono Y, Ikeda R, Hayashi H, et al. C282Y and H63D mutations in the HFE gene have no effect on iron overload disorders in Japan. *Intern Med.* 2001;40:852-856.
  10. Pointon JJ, Viprakasit V, Miles KL, et al. Hemochromatosis gene (HFE) mutations in South East Asia: a potential for iron overload. *Blood Cells Mol Dis.* 2003;30:302-306.
  11. Viprakasit V, Vathesathokit P, Chinchang W, et al. Prevalence of HFE mutations among the Thai population and correlation with iron loading in haemoglobin E disorder. *Eur J Haematol.* 2004; 73:43-49.
  12. Thakur V, Guptan RC, Hashmi AZ, Sakhuja P, Malhotra V, Sarin SK. Absence of hemochromatosis associated Cys282Tyr HFE gene mutation and low frequency of hemochromatosis phenotype in nonalcoholic chronic liver disease patients in India. *J Gastroenterol Hepatol.* 2004;19:86-90.
  13. Garewal G, Das R, Ahluwalia J, Marwaha RK. Prevalence of the H63D mutation of the HFE in north India: its presence does not cause iron overload in beta thalassemia trait. *Eur J Haematol.* 2005;74:333-336.
  14. Agarwal S, Tewari D, Arya V, et al. Status of HFE mutation in thalassemia syndromes in north India. *Ann Hematol.* 2007;86:483-485.
  15. Shukla P, Julka S, Bhatia E, Shah S, Nagral A, Aggarwal R. HFE, hepcidin and ferroportin gene mutations are not present in Indian patients with primary haemochromatosis. *Natl Med J India.* 2006;19:20-23.
  16. Arden KE, Wallace DF, Dixon JL, et al. A novel mutation in ferroportin1 is associated with haemochromatosis in a Solomon Islands patient. *Gut.* 2003;52:1215-1217.
  17. Hayashi H, Wakusawa S, Motonishi S, et al. Genetic background of primary iron overload syndromes in Japan. *Intern Med.* 2006;45:1107-1111.
  18. Hayashi H, Wakusawa S, Yano M, Okada T. Genetic background of Japanese patients with adult-onset storage diseases in the liver. *Hepatol Res.* 2007;37:777-783.
  19. Wallace DF, Browett P, Wong P, Kua H, Ameratunga R, Subramaniam VN. Identification of ferroportin disease in the Indian subcontinent. *Gut.* 2005;54:567-568.
  20. Agarwal S, Sankar VH, Tewari D, Pradhan M. Ferroportin (SLC40A1) gene in thalassemic patients of Indian descent. *Clin Genet.* 2006;70:86-87.
  21. Weatherall DJ, Clegg JB. *The Thalassemia Syndromes.* 4th ed. Oxford, England: Oxford Blackwell Science; 2001.
  22. Stoltzfus RJ, Mullany L, Black RE. Iron deficiency anaemia. In: Ezzati M, Lopez AD, Rodgers A, Murray CJL, eds. *Comparative Quantification of Health Risks: Global and Regional Burden of Disease Attributable to Selected Major Risk Factors.* Vol 1. Geneva, Switzerland: World Health Organization; 2004:163-209.
  23. Merryweather-Clarke AT, Pointon JJ, Shearman JD, Robson KJ. Global prevalence of putative haemochromatosis mutations. *J Med Genet.* 1997;34:275-278.
  24. Merryweather-Clarke AT, Pointon JJ, Jouanolle AM, Rochette J, Robson KJ. Geography of HFE C282Y and H63D mutations. *Genet Test.* 2000;4:183-198.
  25. Steiner M, Ocran K, Genschel J, et al. A homozygous HFE gene splice site mutation (IVS5+1 G/A) in a hereditary hemochromatosis patient of Vietnamese origin. *Gastroenterology.* 2002;122:789-795.
  26. Sohda T, Okubo R, Kamimura S, Ohkawara T. Hemochromatosis with HFE gene mutation in a Japanese patient. *Am J Gastroenterol.* 2001;96: 2487-2488.
  27. Rochette J, Pointon JJ, Fisher CA, et al. Multicentric origin of hemochromatosis gene (HFE) mutations. *Am J Hum Genet.* 1999;64:1056-1062.
  28. Hsu HC, Lin CK, Tsay SH, et al. Iron overload in Chinese patients with hemoglobin H disease. *Am J Hematol.* 1990;34:287-290.
  29. Chim CS, Chan V, Todd D. Hemosiderosis with diabetes mellitus in untransfused Hemoglobin H disease. *Am J Hematol.* 1998;57:160-163.
  30. Chen FE, Ooi C, Ha SY, et al. Genetic and clinical features of hemoglobin H disease in Chinese patients. *N Engl J Med.* 2000;343:544-550.
  31. Chan V, Wong MS, Ooi C, et al. Can defects in transferrin receptor 2 and hereditary hemochromatosis genes account for iron overload in HbH disease? *Blood Cells Mol Dis.* 2003;30:107-111.
  32. Lee PL, Beutler E, Rao SV, Barton JC. Genetic abnormalities and juvenile hemochromatosis: mutations of the HJV gene encoding hemojuvelin. *Blood.* 2004;103:4669-4671.
  33. Takagi J. Structural basis for ligand recognition by RGD (Arg-Gly-Asp)-dependent integrins. *Biochem Soc Trans.* 2004;32:403-406.
  34. Pagani A, Silvestri L, Nai A, Camaschella C. Hemojuvelin N-terminal mutants reach the plasma membrane but do not activate the hepcidin response. *Haematologica.* 2008;93:1466-1472.
  35. Silvestri L, Pagani A, Fazi C, et al. Defective targeting of hemojuvelin to plasma membrane is a common pathogenetic mechanism in juvenile hemochromatosis. *Blood.* 2007;109:4503-4510.
  36. Donovan A, Brownlie A, Zhou Y, et al. Positional cloning of zebrafish ferroportin1 identifies a conserved vertebrate iron exporter. *Nature.* 2000; 403:776-781.
  37. McKie AT, Marciani P, Rolfs A, et al. A novel duodenal iron-regulated transporter, IREG1, implicated in the basolateral transfer of iron to the circulation. *Mol Cell.* 2000;5:299-309.
  38. Devalia V, Carter K, Walker AP, et al. Autosomal dominant reticuloendothelial iron overload associated with a 3-base pair deletion in the ferroportin 1 gene (SLC11A3). *Blood.* 2002;100:695-697.
  39. Liu XB, Yang F, Haile DJ. Functional consequences of ferroportin 1 mutations. *Blood Cells Mol Dis.* 2005;35:33-46.
  40. De Domenico I, Nemeth E, Nelson JM, et al. The hepcidin-binding site on ferroportin is evolutionarily conserved. *Cell Metab.* 2008;8:146-156.
  41. Drakesmith H, Schimanski LM, Ormerod E, et al. Resistance to hepcidin is conferred by hemochromatosis-associated mutations of ferroportin. *Blood.* 2005;106:1092-1097.
  42. Schimanski LM, Drakesmith H, Merryweather-Clarke AT, et al. In vitro functional analysis of human ferroportin (FPN) and hemochromatosis-associated FPN mutations. *Blood.* 2005;105: 4096-4102.
  43. Barton JC, Bertoli LF, Rothenberg BE. Peripheral blood erythrocyte parameters in hemochromatosis: evidence for increased erythrocyte hemoglobin content. *J Lab Clin Med.* 2000;135:96-104.
  44. Bhansali A, Banerjee PK, Dash S, Radotra B, Dash RJ. Pituitary and testicular involvement in primary haemochromatosis. A case report. *J Assoc Physicians India.* 1992;40:757-759.
  45. Hachiya M, Watanabe H, Tsukimoto I, Fujisawa T. Hereditary hemochromatosis not associated with common HFE gene mutation in Japanese siblings. *J Pediatr Gastroenterol Nutr.* 2001;32:501-503.
  46. Kng C, Ng FH, Ng WF, et al. A Chinese patient with non-HFE-linked iron overload. *J Clin Gastroenterol.* 2001;33:69-71.
  47. Panigrahi I, Ahmad F, Kapoor R, Sharma PK, Makharia G, Saxena R. Evidence for non-HFE linked hemochromatosis in Asian Indians. *Indian J Med Sci.* 2006;60:491-495.